

Improved Basic Symmetry Tests for MOSFET Models

Workshop on Compact Modeling
9-11 May, 2006

Colin McAndrew
Freescale Semiconductor



Freescale™ and the Freescale logo are trademarks of Freescale Semiconductor, Inc. All other product or service names are the property of their respective owners. © Freescale Semiconductor, Inc. 2005.

Outline

- Symmetry is a critical property of MOSFET models
- The standard test for MOSFET model symmetry is the GST (Gummel Symmetry Test)
 - important as it defines biasing that maps the 4 independent terminal biases into a single symmetric (differential) bias
 - maps MOSFET behavior into an odd function of this bias
- GST is **wrong** if there is gate and/or substrate current
- GST does **not** evaluate AC (charge) model symmetry
- Therefore there is a need for
 - a DC symmetry test valid with gate and/or substrate current
 - symmetry tests for AC aspects of a model
- New MOSFET symmetry tests are defined here
 - preserve biasing and odd function approach of GST
 - DC and AC, valid in presence of gate and substrate currents



Slide 2

Freescale™ and the Freescale logo are trademarks of Freescale Semiconductor, Inc. All other product or service names are the property of their respective owners. © Freescale Semiconductor, Inc. 2005.

DC MOSFET Currents

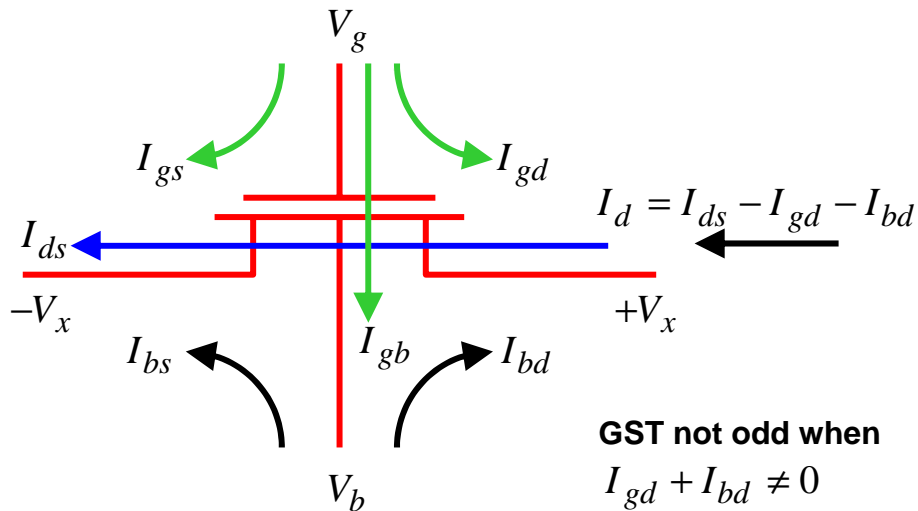

Slide 3

Freescale™ and the Freescale logo are trademarks of Freescale Semiconductor, Inc. All other product or service names are the property of their respective owners. © Freescale Semiconductor, Inc. 2005.

New DC Symmetry Test

- Don't use drain current, use

$$I_x = 0.5(I_d - I_s) = I_{ds} - 0.5(I_{gd} - I_{gs}) - 0.5(I_{bd} - I_{bs})$$

- Plot I_x and its derivatives versus V_x
- Not only tests the symmetry of I_{ds} model
- Also tests the symmetry of gate and substrate current models



Slide 4

Freescale™ and the Freescale logo are trademarks of Freescale Semiconductor, Inc. All other product or service names are the property of their respective owners. © Freescale Semiconductor, Inc. 2005.

AC MOSFET Currents

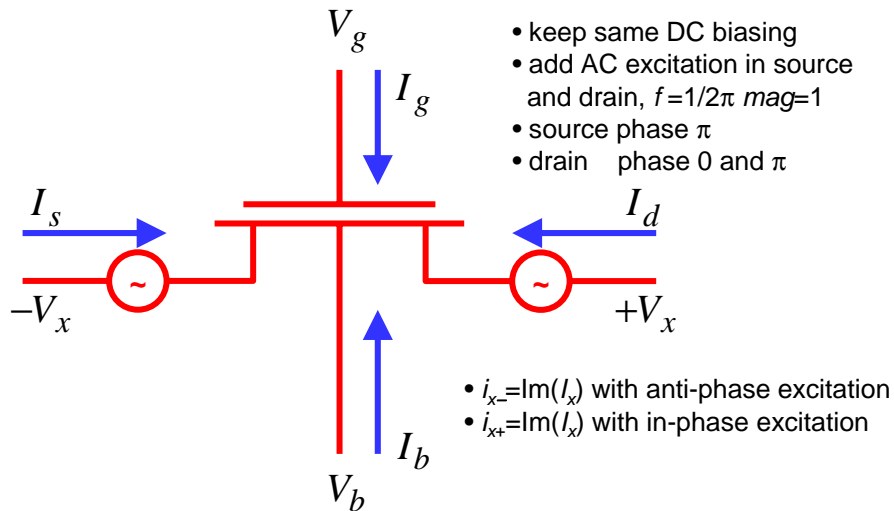

Slide 5

Freescale™ and the Freescale logo are trademarks of Freescale Semiconductor, Inc. All other product or service names are the property of their respective owners. © Freescale Semiconductor, Inc. 2005.

New AC Symmetry Tests

- 3 independent charges in MOSFET models
- need 3 independent quantities to check all of these vs. V_x
- can do simple normalization as well

$$\delta_{cg} = i_{g-} / i_{g+} = (C_{gs} - C_{gd}) / (C_{gs} + C_{gd})$$

$$\delta_{cb} = i_{b-} / i_{b+} = (C_{bs} - C_{bd}) / (C_{bs} + C_{bd})$$

- defining a test for source and drain charge is harder, some apparently good candidates are symmetric even if a charge model is asymmetric, or only check gate and bulk charge again

$$\delta_{csd} = \frac{(i_{s-} + i_{d-}) + (i_{s+} - i_{d+})}{(i_{s-} - i_{d-}) + (i_{s+} + i_{d+})} = \frac{C_{ss} - C_{dd}}{C_{ss} + C_{dd}}$$



Slide 6

Freescale™ and the Freescale logo are trademarks of Freescale Semiconductor, Inc. All other product or service names are the property of their respective owners. © Freescale Semiconductor, Inc. 2005.

DC Symmetry Test Results

- current looks OK, derivative shows problem

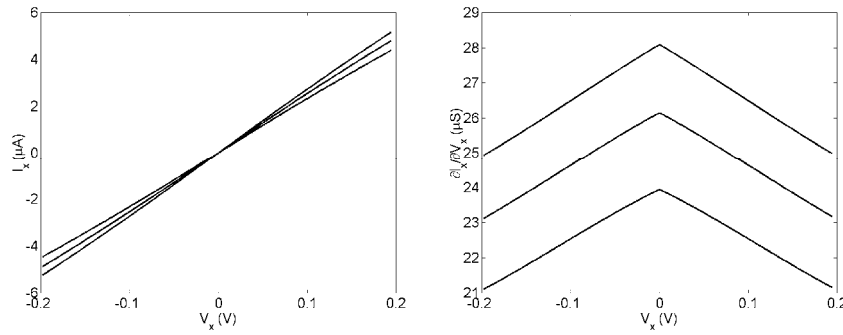

Slide 7

Freescale™ and the Freescale logo are trademarks of Freescale Semiconductor, Inc. All other product or service names are the property of their respective owners. © Freescale Semiconductor, Inc. 2005.

DC Symmetry Test Results

- results from a perfect model

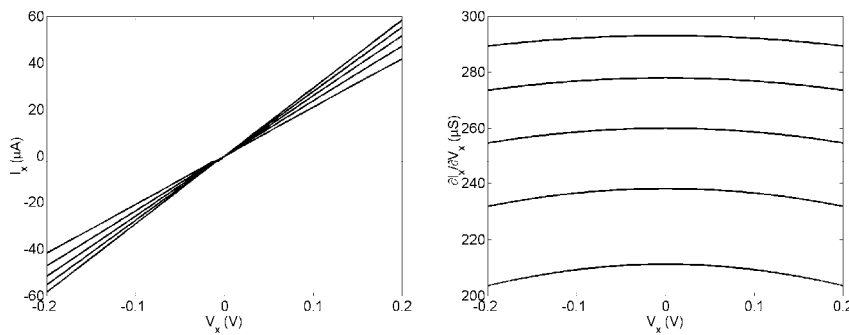

Slide 8

Freescale™ and the Freescale logo are trademarks of Freescale Semiconductor, Inc. All other product or service names are the property of their respective owners. © Freescale Semiconductor, Inc. 2005.

DC Symmetry Test Results

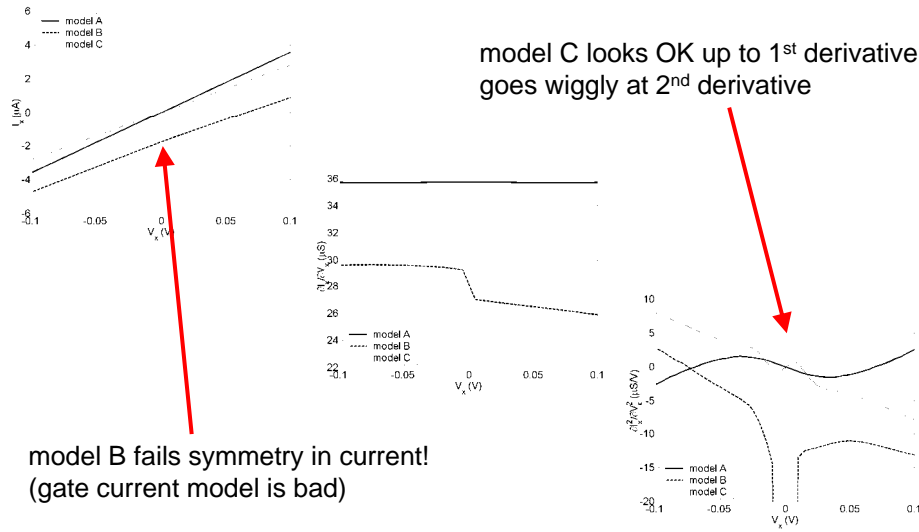

Slide 9

Freescale™ and the Freescale logo are trademarks of Freescale Semiconductor, Inc. All other product or service names are the property of their respective owners. © Freescale Semiconductor, Inc. 2005.

Gate Charge Symmetry Test

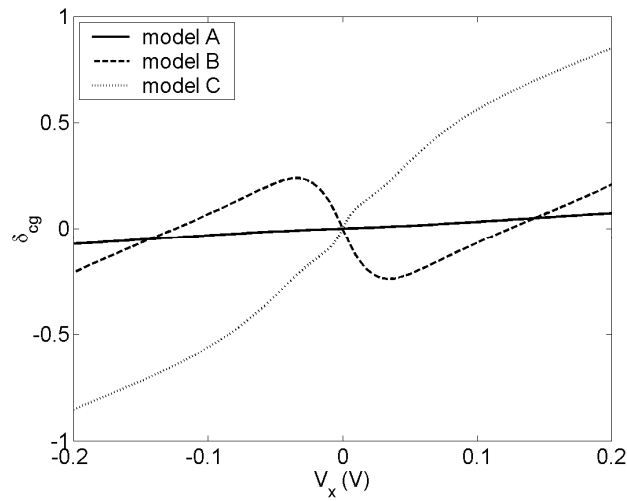

only
A is
good



Slide 10

Freescale™ and the Freescale logo are trademarks of Freescale Semiconductor, Inc. All other product or service names are the property of their respective owners. © Freescale Semiconductor, Inc. 2005.

Gate Charge Symmetry Test, 1st Derivative

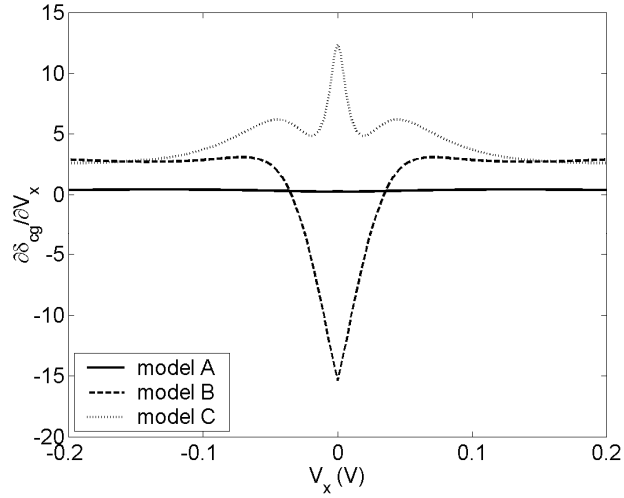

only
A is
good



Slide 11

Freescale™ and the Freescale logo are trademarks of Freescale Semiconductor, Inc. All other product or service names are the property of their respective owners. © Freescale Semiconductor, Inc. 2005.

Gate Charge Symmetry Test, 2nd Derivative

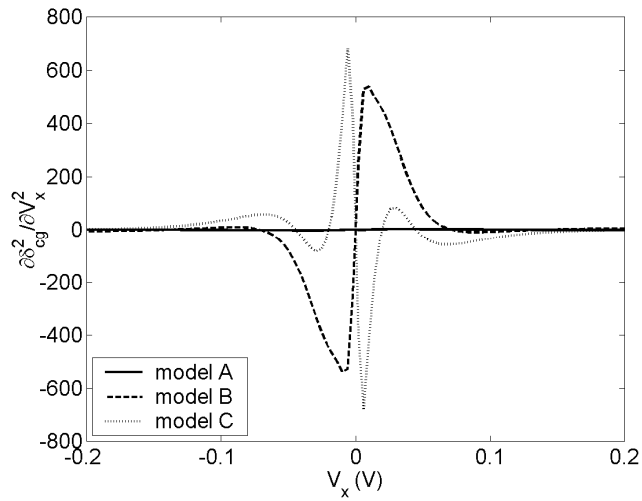

only
A is
good



Slide 12

Freescale™ and the Freescale logo are trademarks of Freescale Semiconductor, Inc. All other product or service names are the property of their respective owners. © Freescale Semiconductor, Inc. 2005.

Gate Charge Symmetry

pass

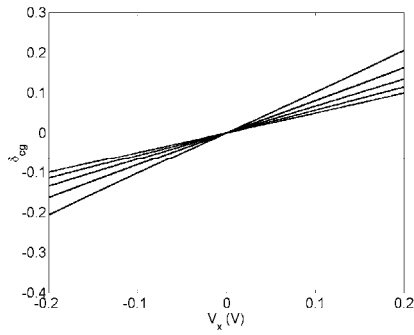

fail

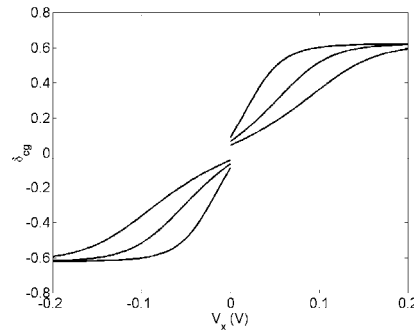

Slide 13

Freescale™ and the Freescale logo are trademarks of Freescale Semiconductor, Inc. All other product or service names are the property of their respective owners. © Freescale Semiconductor, Inc. 2005.

Bulk Charge Symmetry

pass

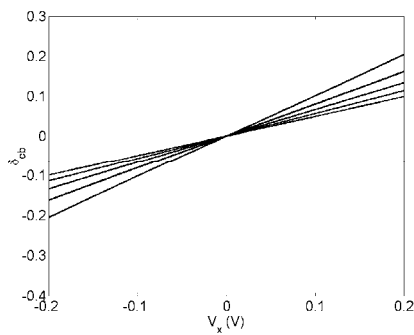

fail

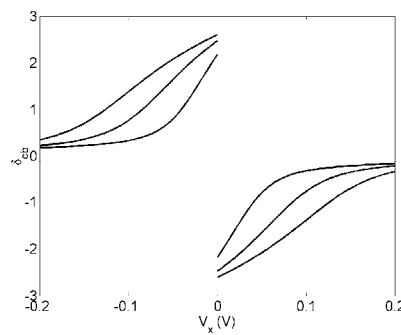

Slide 14

Freescale™ and the Freescale logo are trademarks of Freescale Semiconductor, Inc. All other product or service names are the property of their respective owners. © Freescale Semiconductor, Inc. 2005.

Source-Drain Charge Symmetry

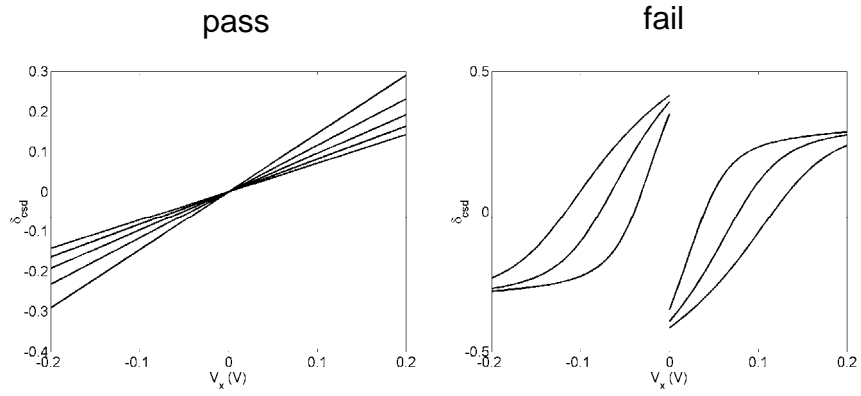

Slide 15

Freescale™ and the Freescale logo are trademarks of Freescale Semiconductor, Inc. All other product or service names are the property of their respective owners. © Freescale Semiconductor, Inc. 2005.